



**GLENSOUND
ELECTRONICS LTD**

GS-CU001

COMMENTATOR UNIT

PRODUCT DETAILS

GS-CU001 Commentator Unit

Handbook Contents

Issue 3, March 2004

	<u>Description</u>	<u>Drawing No.</u>
1.	GS-CU001 Overall View	
2.	GS-CU001 Block Diagram	
3.	GS-CU001 Labelled View 1 – Top Panel	
4.	GS-CU001 Labelled View 2 – Front and Rear Panels	
5.	GS-CU001 Panel Features – Explanation	
6.	Circuit Diagram – Upper I/O PCB	GSR30
7.	Circuit Diagram – Lower I/O PCB	GSR31
8.	Circuit Diagram – Control Panel PCB	GSR32 (3 sheets)
9.	Circuit Diagram – Front I/O PCB	GSR33 (3 sheets)

← 277 mm →

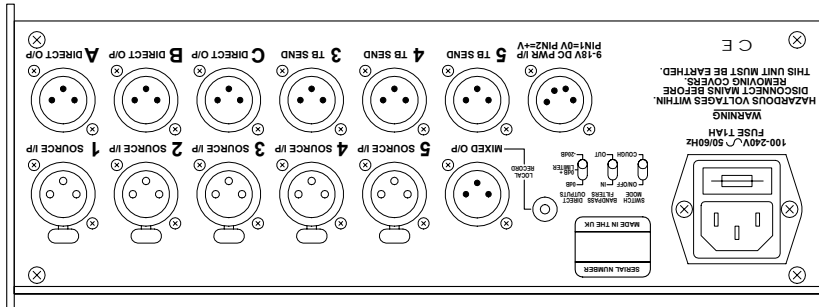

← 105 mm →

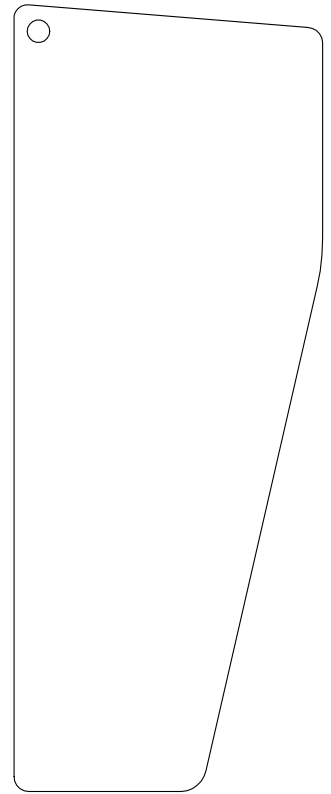

↑ 266 mm ↓

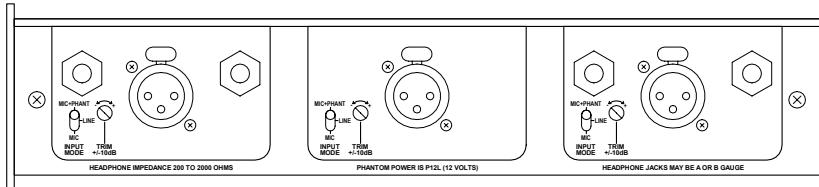
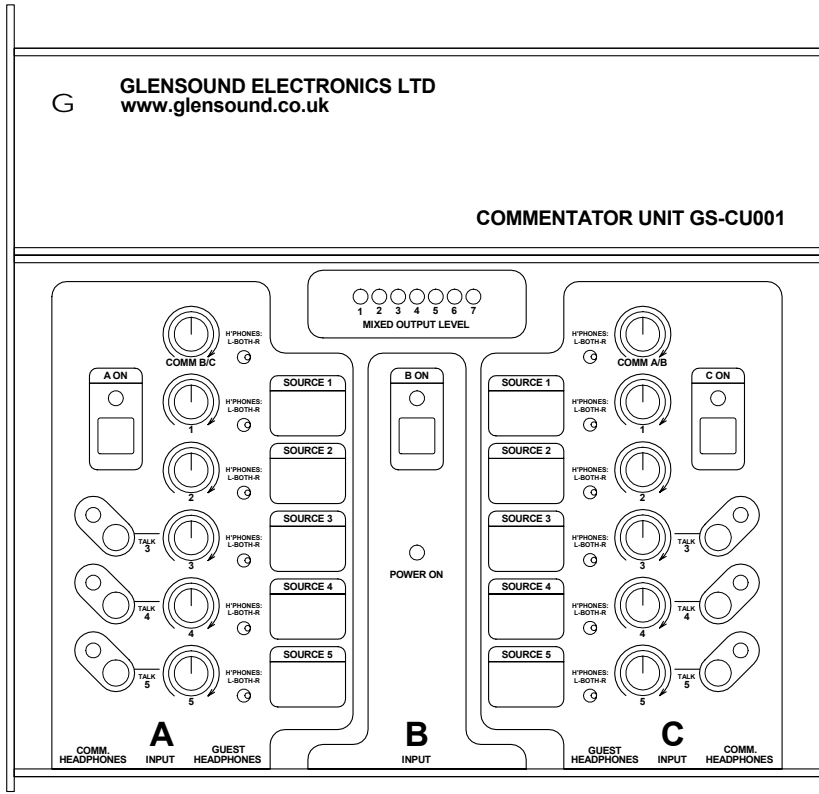

ISSUE	1	DRG. REF.	GS-CU001
DATE	3/4/03		COMM'TORS UNIT
DRAWN	SJL		OVERALL VIEW
			G GLENSOUND ELECTRONICS LTD.

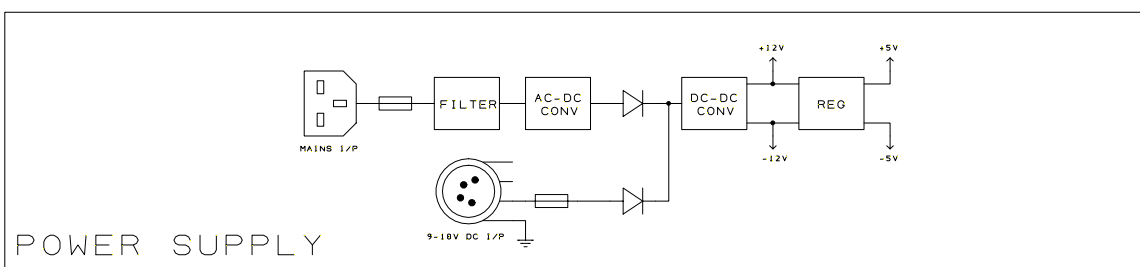
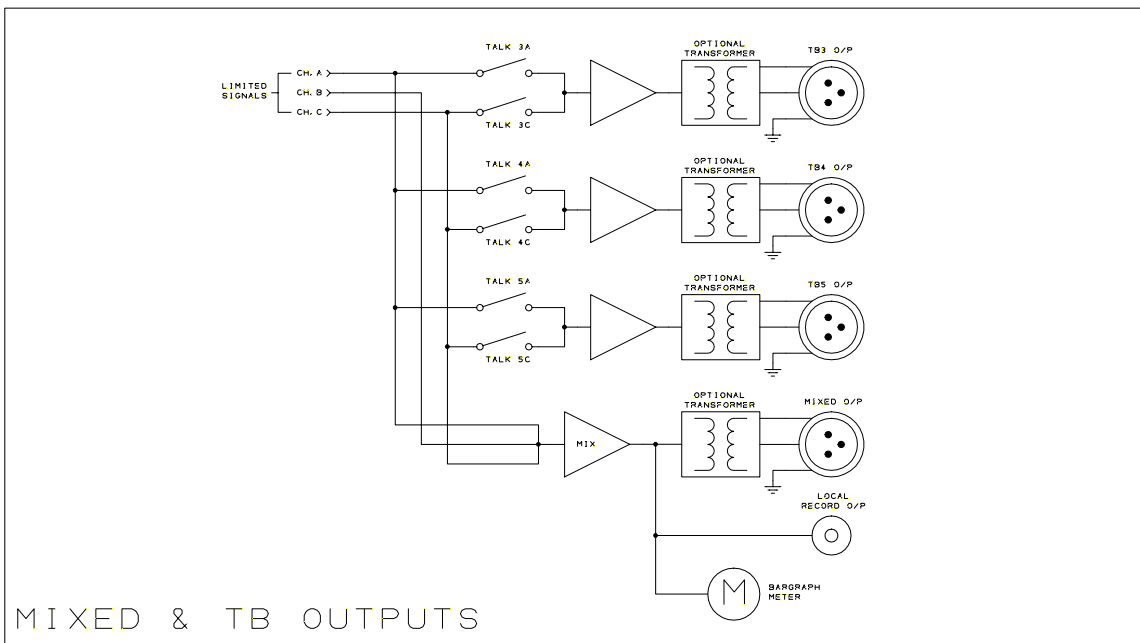
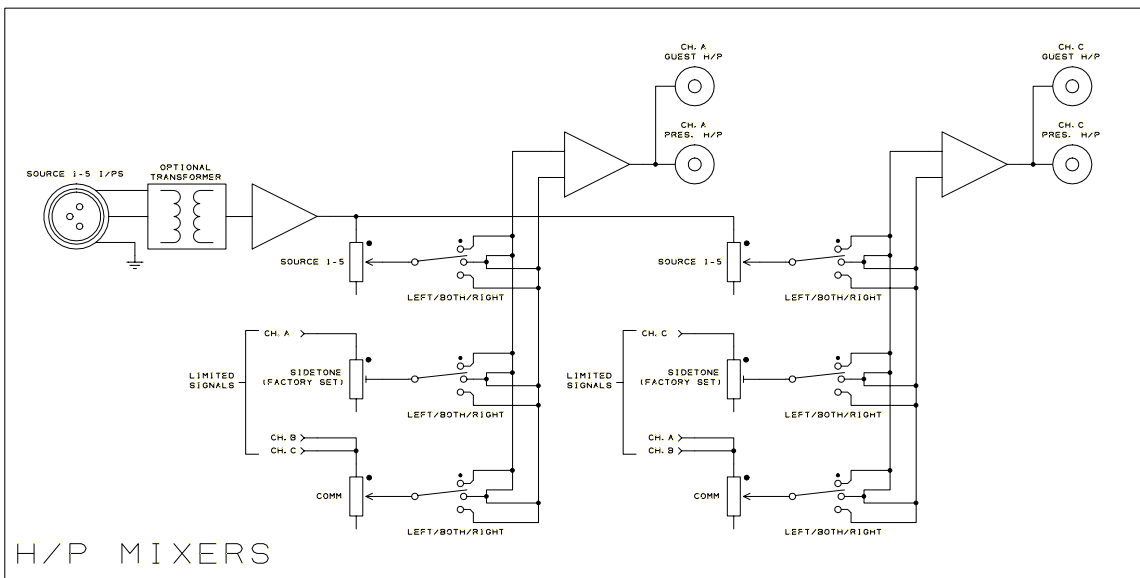
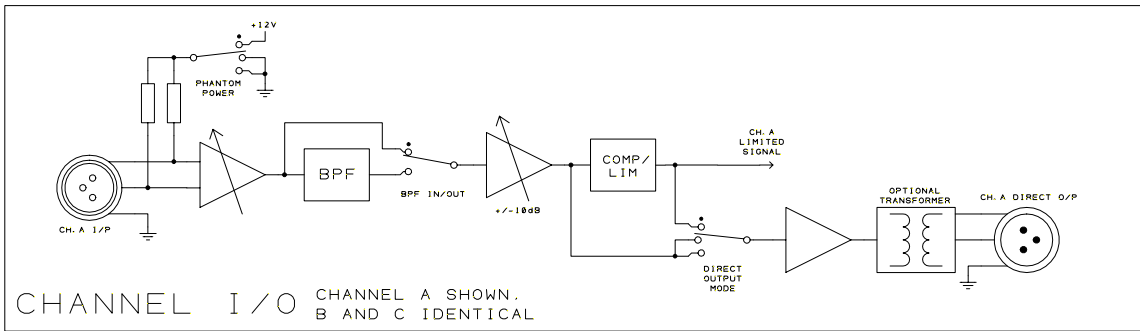

G GLENSOUND
ELECTRONICS LTD.

ISSUE	1	DATE	7/4/03	DRAWN	SJL
	(c) GLENSOUND		SUBJECT GS-CU001 COMMENTATOR UNIT		
DRG. REF. GS-CU001 BLOCK DIAGRAM					

G GLENSOUND ELECTRONICS LTD
www.glen sound.co.uk

COMMENTATOR UNIT GS-CU001

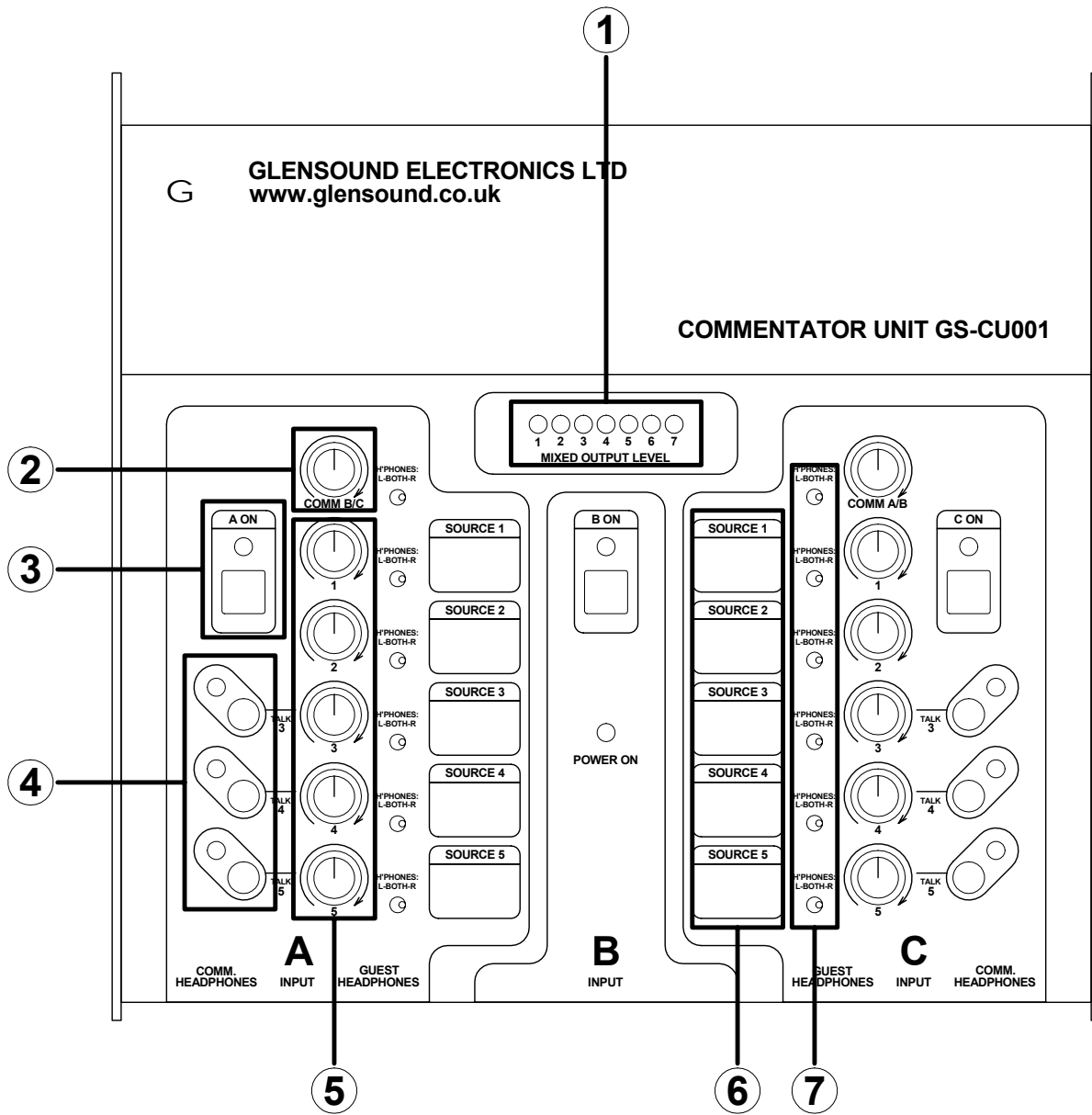

ISSUE	1	DRG. REF.	GS-CU001
DATE	3/4/03		COMMENTATORS UNIT
DRAWN	SJL		PANEL FEATURES 1

G GLENSOUND ELECTRONICS LTD.

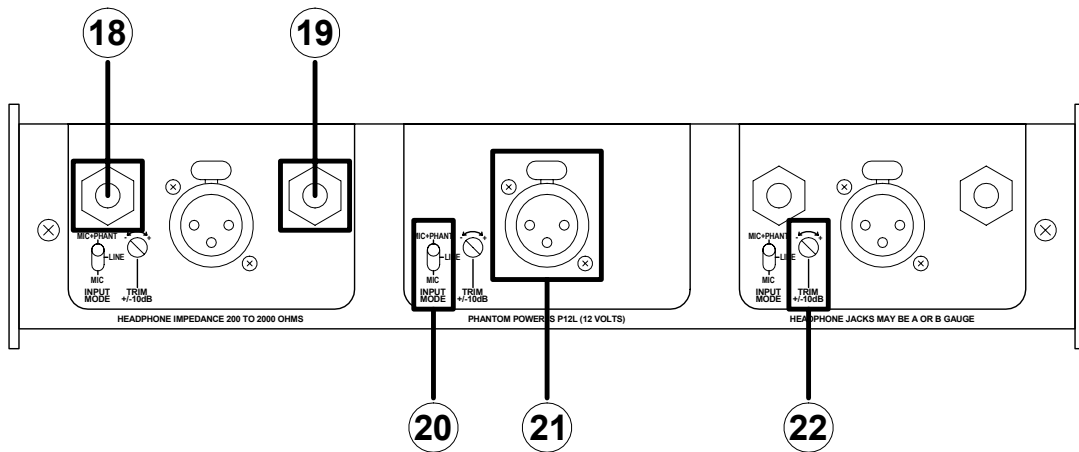
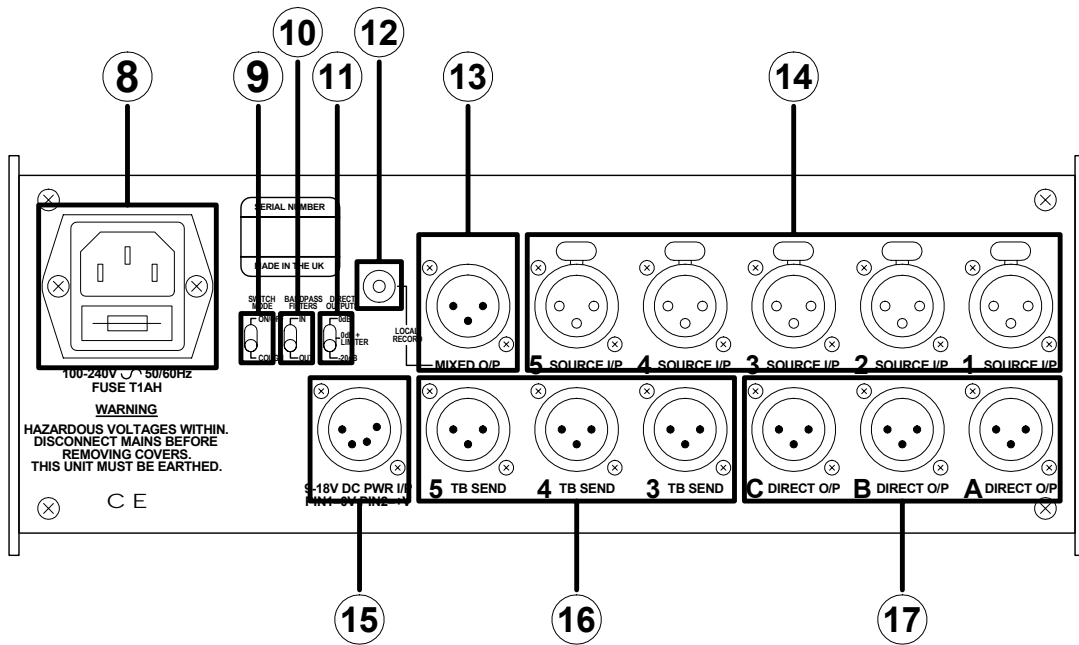

ISSUE	1	DRG. REF.	GS-CU001 COMM TORS UNIT PANEL FEATURES 2	G GLENSOUND ELECTRONICS LTD.
DATE	3/4/03			
DRAWN	SJL			

GS-CU001 Panel Features – refer to numbered diagrams

1. Seven-segment LED bargraph meter

This has a PPM characteristic and follows the level on the MIXED output. The scale is labelled from PPM1 to 7 with PPM4 equating to 0dBu at the output. Note: since the MIXED output is always fed via the compressor/limiter, unlimited DIRECT outputs may exceed the level displayed on the meter.

2. COMM level control (channels A and C only)

Controls the amount of signal fed from the “other” two channels into the headphone mix.

3. ON switches

The behaviour of these switches alters according to the setting of the rear panel SWITCH MODE selector. In ON/OFF mode, brief actuation of the switches will toggle the corresponding channel on and off. In COUGH mode, the channels remain permanently on except whilst the ON switch is held down, i.e. the switch acts as a mute.

Panel indicators display the status of each channel. When off, a channel feeds no signal to either the DIRECT or MIXED outputs but talkback remains possible.

4. Talkback (TB) switches (channels A and C only) – see also “Switch Options” section below

Pressing any of the three talkback buttons feeds the channel signal to the correspondingly numbered talkback output. The “smart” switches have two modes of operation – brief pushes of the switch toggle in and out of talkback mode (“lazy” talkback), while longer pushes engage talkback only for the period that the switch is depressed (“momentary” talkback).

Panel indicators display the status of each of the three talkback circuits. When talkback is active, the channel feeds no signal to either the DIRECT or MIXED outputs.

Note: In many cases, the three talkback circuits will have a corresponding return talkback signal fed back to three of the SOURCE inputs. The talkback circuits are therefore labelled 3, 4 and 5 in order to provide a loose association with source inputs 3, 4 and 5 under these circumstances. However, the talkback send outputs are entirely independent of the source inputs and may be used in any configuration required.

5. SOURCE level controls (channels A and C only)

Control the amount of signal fed from the correspondingly numbered SOURCE input into the headphone mix.

6. Labelling areas

Convenient areas for denoting the purpose of each SOURCE input and/or talkback circuit, using sticky labels, chinagraph pencil etc.

7. Headphone routing switches

Allow each of the sources contributing to the headphone mix to be fed to just the left channel, just the right channel or both channels of the headphones as preferred.

8. IEC mains input

Accepts worldwide mains voltages without adjustment. Power consumption is less than 10W. The inlet also houses a 1A slow-blow HRC fuse and in the event of failure this should be replaced with an identical part to ensure continuing protection.

9. SWITCH MODE selector

Allows the operation of the channel ON switches to be chosen as either ON/OFF or COUGH (see above).

10. BANDPASS FILTER selector

Allows an optional bandpass filter with -3dB rolloff points of approx. 80Hz and 12.5kHz to be applied to the channel audio signals. Note: the filter is only applied when the channel input is set to MIC or MIC+PHANT.

11. DIRECT OUTPUTS level selector

Allows one of three level options to be selected for the three DIRECT channel outputs:

The 0dB+LIM position feeds the DIRECT outputs from the internal compressor/limiter at a nominal lineup level of 0dBu. With excessive input levels automatically restricted, this is the optimal choice for simpler installations.

The 0dB position feeds the DIRECT outputs with the uncompressed input signal at a nominal lineup level of 0dBu. This option should be selected when peak signal level is to be controlled manually or by offboard equipment.

The -20dB position feeds the DIRECT outputs with the uncompressed input signal at a nominal lineup level of -20dBu. This option delivers maximum headroom in applications where peak signal level is to be controlled manually or by offboard equipment.

12. LOCAL RECORD output

A 3.5mm jack socket – accepting either mono or stereo jack plugs – carrying an unbalanced signal at -14dBu for local recording onto MiniDisk, etc. The signal presented is a combination of the MIXED output (i.e. the overall output of the unit) and the signal being received on SOURCE input 1 (e.g. return cue from studio, etc.).

13. MIXED output

A balanced mono output carrying the combined output of all three audio channels at a nominal lineup level of 0dBu. Signals sent to the MIXED output are always processed by the compressor/limiter. The level at the MIXED output is displayed on the front panel LED meter.

14. SOURCE inputs

Five balanced mono inputs. Each contributes to the channel A and C headphone mixes via a front panel level pot and panning switch, and may be used for cue/programme audio, talkback returns, etc.

15. DC POWER input

A four-pin male XLR via which the GS-CU001 may be powered from an external DC source lying in the range +9V to +18V. Power consumption is less than 10W. Should both mains and external DC power be applied, power drain will be transferred from the mains to the DC supply once the DC voltage exceeds +12V.

16. TB SEND outputs

Three balanced mono outputs with a nominal lineup level of 0dBu. Channel A and C audio is fed to these outputs when the correspondingly numbered talkback circuit is activated by the front panel buttons.

17. DIRECT outputs

Three balanced mono outputs, the lineup level of which is controlled by the DIRECT OUTPUTS selector (see above). These carry the individual output signals of the three audio channels and can be used when mixing is to be performed by offboard equipment.

18. COMM HEADPHONES (channels A and C only)

A stereo 6.35mm jack socket (capable of accepting both A and B gauge jack plugs) carrying the headphone mix. Sources contributing to this mix are SOURCE inputs 1-5, the combined signal from the "other" two channels and own channel sidetone. All these sources, with the exception of sidetone, have a front panel level control and panning switch allowing customisation of the headphone mix.

19. GUEST HEADPHONES (channels A and C only)

Two stereo 6.35mm jack sockets (capable of accepting both A and B gauge jack plugs) carrying a copy of the headphone mixes from channels A and C. A guest being interviewed may be provided with a headphone feed from whichever channel is appropriate.

20. INPUT MODE selectors

Three position recessed switches which determine the sensitivity of the channel audio inputs. In each position the input gain may be trimmed +/-10dB around its nominal value (see below).

In LINE mode, the input sensitivity suits line level signals.

In MIC mode, the input sensitivity suits non-phantom powered microphones.

In MIC+PHANT mode, the input sensitivity suits phantom powered microphones and +12V phantom power is supplied to the input socket.

21. CHANNEL inputs

Three balanced mono audio inputs feeding the three input channels. Sensitivity is determined by the INPUT MODE selector (see above).

22. TRIM controls

A continuous rotary control allowing the input gain to be trimmed +/-10dB about its nominal value. In LINE mode this may be used to accommodate both consumer and professional levels, while in MIC mode the unit may be adapted ("on-the-fly" if necessary) to different user and microphone characteristics.

Switch Options

Units with serial numbers greater than 126 are fitted with enhanced firmware that allows the operation of some front panel controls to be altered by the user. This allows the functionality of the unit to be tailored to meet changing requirements and fulfil different tasks.

Changes are made by holding down specific combinations of front panel buttons *as power is applied to the unit*. For safety reasons the unit only responds to change instructions at the moment of power-up and applying the switch combinations at any other time will have no effect other than the usual functions of the switches involved. Combinations of switches other than those detailed below are ignored.

Only one change may be made at a time – to make multiple changes, remove power from the unit after each change then reapply it while holding down the next switch combination required. Apart from the restrictions described, the number of changes is unlimited and they may be applied at any time.

The unit configuration is stored in internal non-volatile memory and retained even when the unit is unpowered.

Supported options:

- Holding both C ON and TALK3-C selects normal operation of the TB switches, whereby brief depressions of the switches toggle talkback on and off and longer presses engage talkback for only as long as the switch is pressed. This is the default mode of operation.
- Holding both C ON and TALK4-C selects momentary-only operation of the TB switches, whereby talkback is only engaged for as long as the switch is pressed.
- Holding both C ON and TALK5-C selects latching-only operation of the TB switches, whereby each depression of the switch, however long or short, toggles talkback from on to off or vice versa.
- Holding both C ON and B ON toggles whether the channel A and C microphone signals are muted when one of their corresponding talkback channels is active. The default mode of operation is for muting to be enabled.

A Further firmware revision was made to allow the switch operation of the Talkback and Microphone circuits to be linked together. This firmware is fitted to all versions with a serial no: 642 or higher.

- Holding both A ON and C ON allows the A & C mic switches to be linked.
- Holding both TALK3-A and TALK3-C allows the TALK3 switches to be linked.
- Holding both TALK4-A and TALK4-C allows the TALK4 switches to be linked.
- Holding both TALK5-A and TALK5-C allows the TALK5 switches to be linked.
- Holding both B ON and TALK3-A allows the B ON switch to toggle all the switches between linked switches and normal operation. When in this mode if the B ON switch is on then any pairs of switches that have been set to be linked will operate in the linked mode and if the B ON switch is off then these same switches will operate individually.
- NOTE: The above programming operations 'toggle' between turning the facility on and off.

GS-CU001 Connectors

Signal inputs:

Female XLR-3. Pin 1 = GND, Pin 2 = hot (phase), Pin 3 = cold (antiphase)

Signal outputs:

Male XLR-3. Pin 1 = GND, Pin 2 = hot (phase), Pin 3 = cold (antiphase)

Local record:

3.5mm stereo jack socket. Tip = signal, Ring = signal, Sleeve = GND. Mono plugs may be used without damage.

Headphone outputs:

6.35mm stereo jack socket. Tip = L signal, Ring = R signal, Sleeve = GND. Accept A- or B-gauge jack plugs.

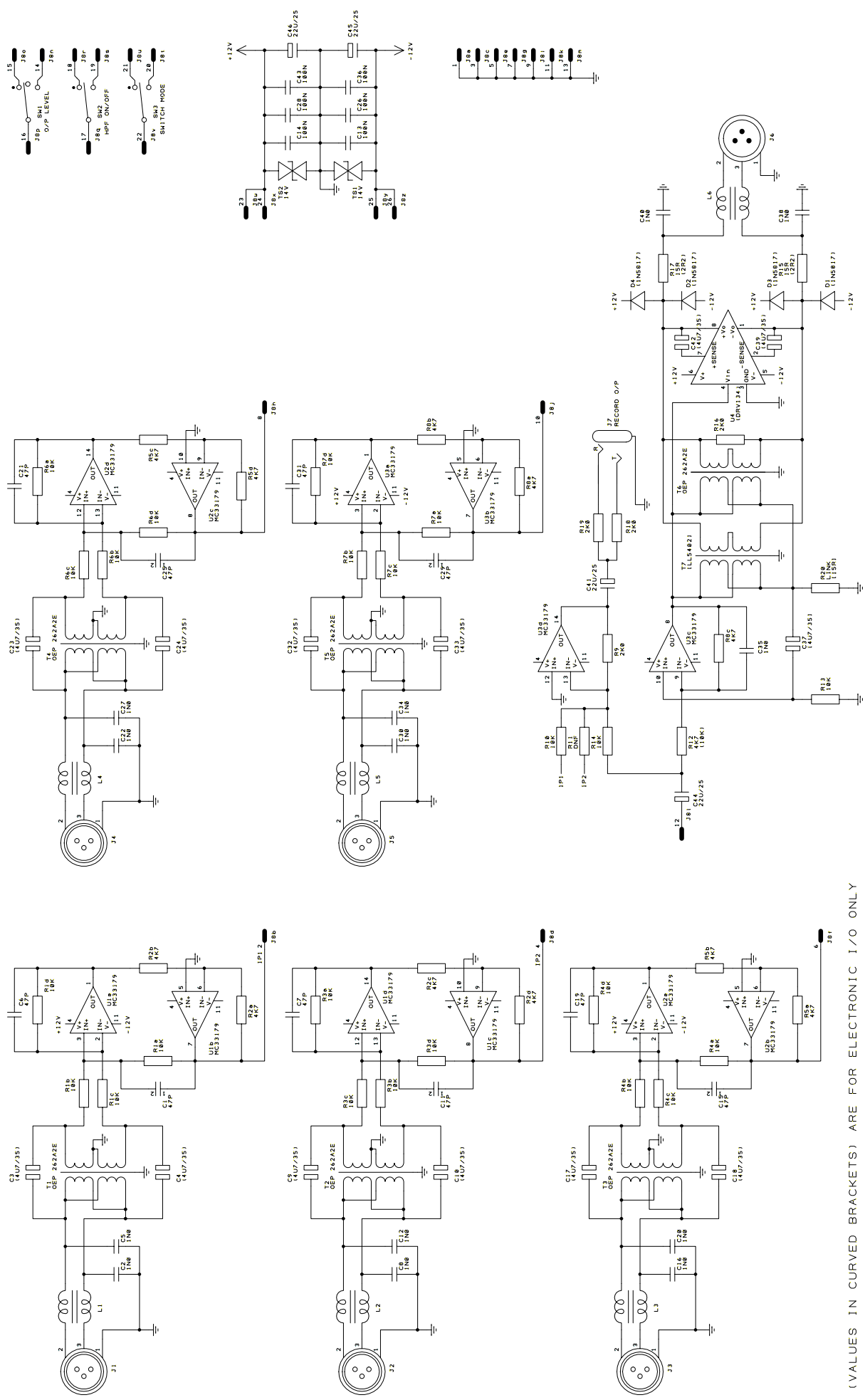

(VALUES IN CURVED BRACKETS) ARE FOR ELECTRONIC I/O ONLY
 (VALUES IN SQUARE BRACKETS) ARE FOR LUNDAHL O/P ONLY

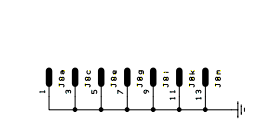
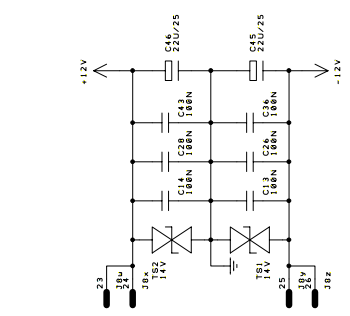
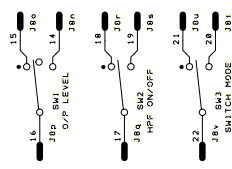

(C) GLENSOUND		G GLENSOUND ELECTRONICS LTD.
ISSUE	2	SUBJECT COMM. UNIT I/O
DATE	8/5/03	DRG. REF. CSR30
DRAWN	S.J.L.	

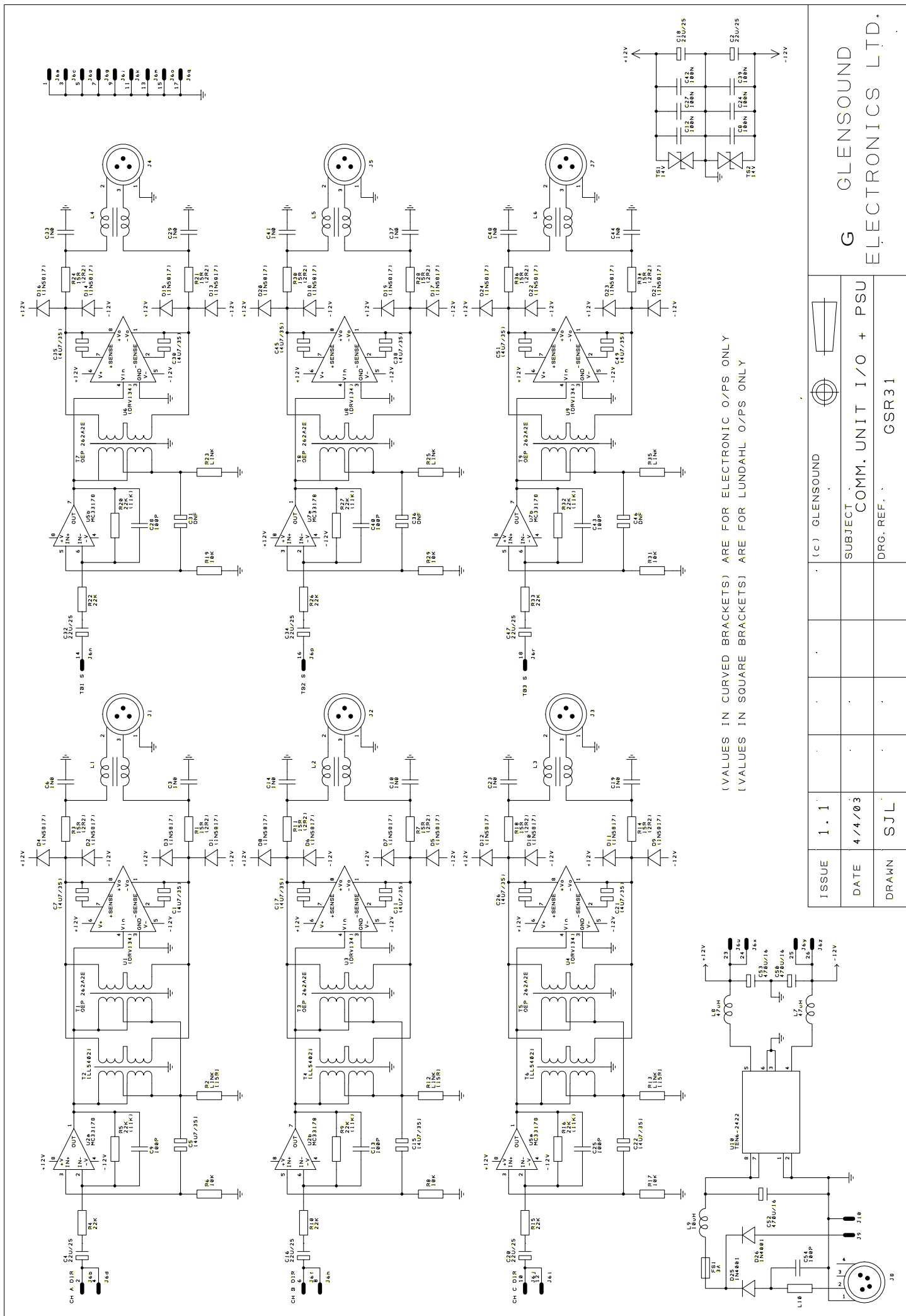

(VALUES IN CURVED BRACKETS) ARE FOR ELECTRONIC O/PS ONLY
 (VALUES IN SQUARE BRACKETS) ARE FOR LUNDAHL O/PS ONLY

ISSUE	1.1	(C) GLENSOUND
DATE	4/4/03	SUBJECT COMM. UNIT I/O + PSU
DRAWN	SJL	DRG. REF. GSR31

G GLENSOUND
 ELECTRONICS LTD.



(C) GLEN SOUND

SUBJECT GS-CU001 CONTROL PANEL
HEADPHONE MONITORING

DRG. REF. GSR32 SHEET 1

ISSUE	2
DATE	8/5/03
DRAWN	SJL

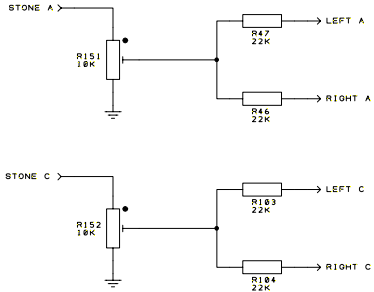
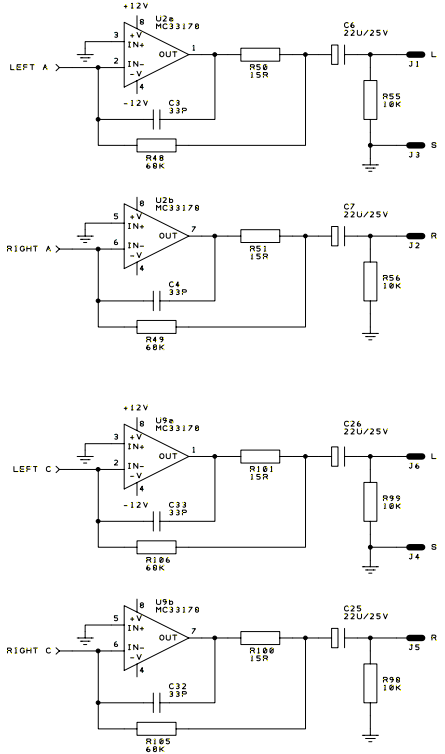
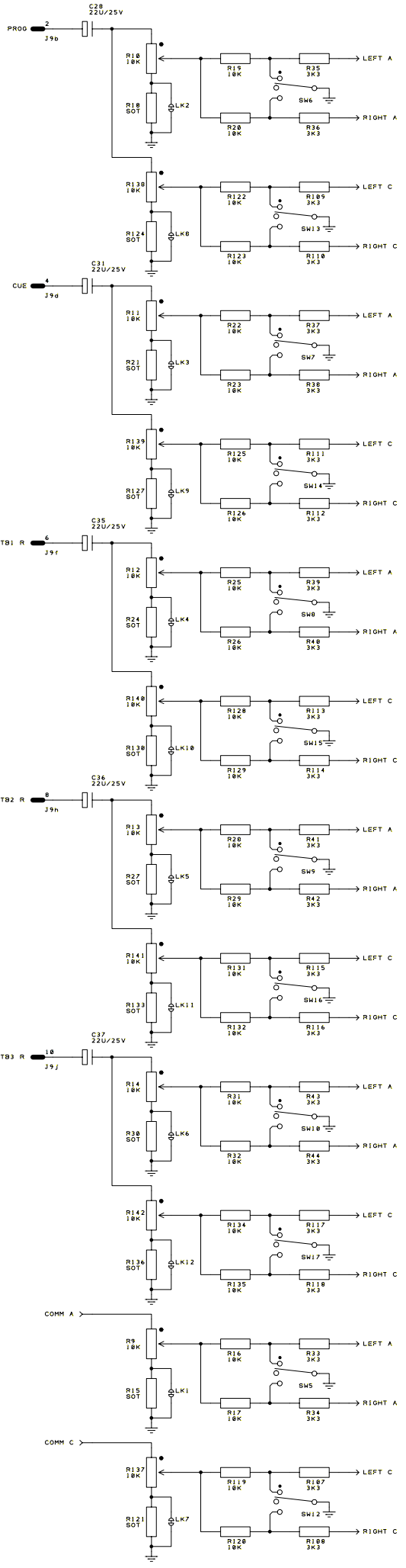

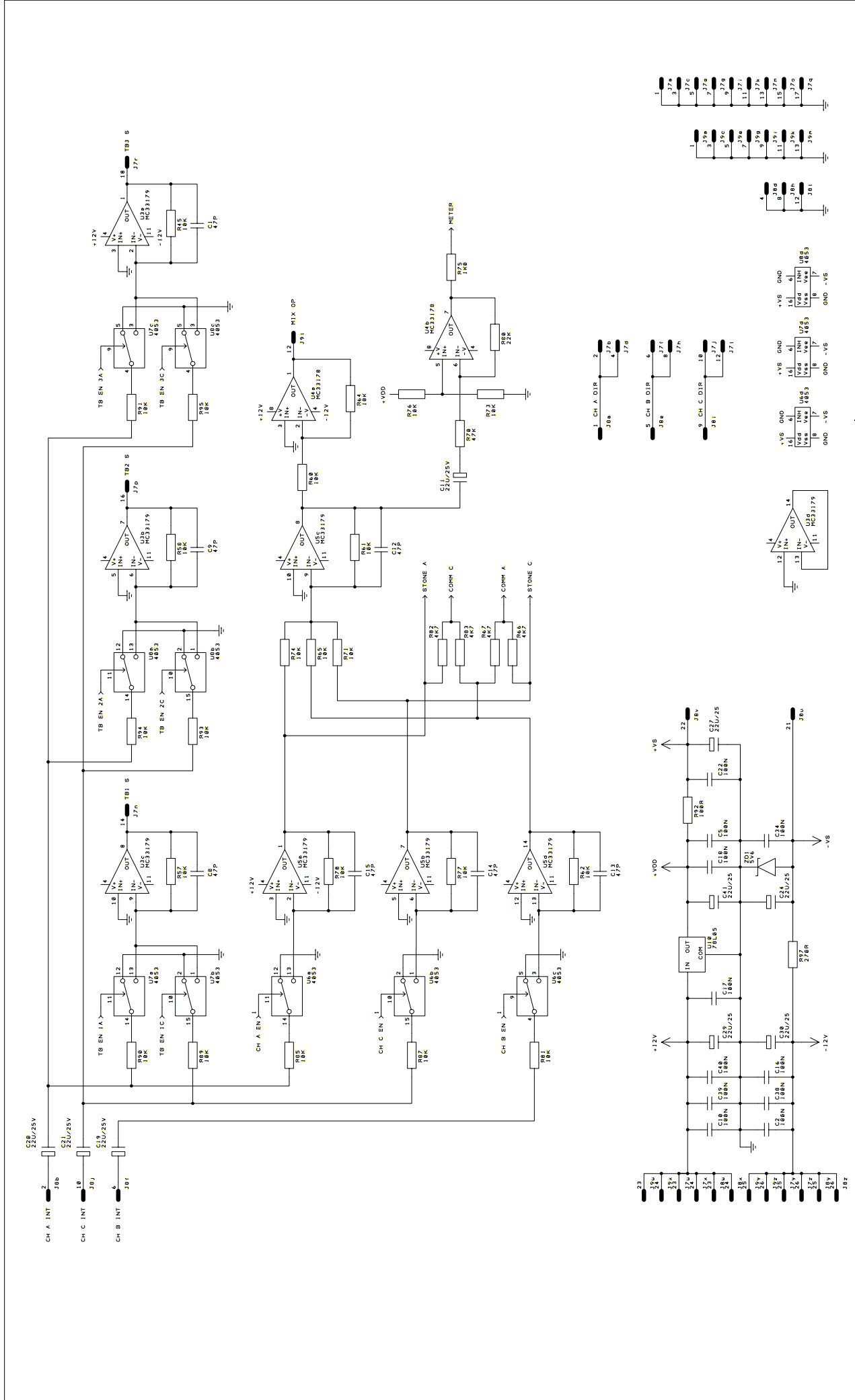

(C) GLENSOUND			G GLENSOUND ELECTRONICS LTD.	
ISSUE	2	SUBJECT GS-CU001 CONTROL PANEL AUDIO ROUTING/PSU		
DATE	8/5/03	DRG. REF. GSR32 SHEET 2		
DRAWN	SJL			

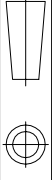
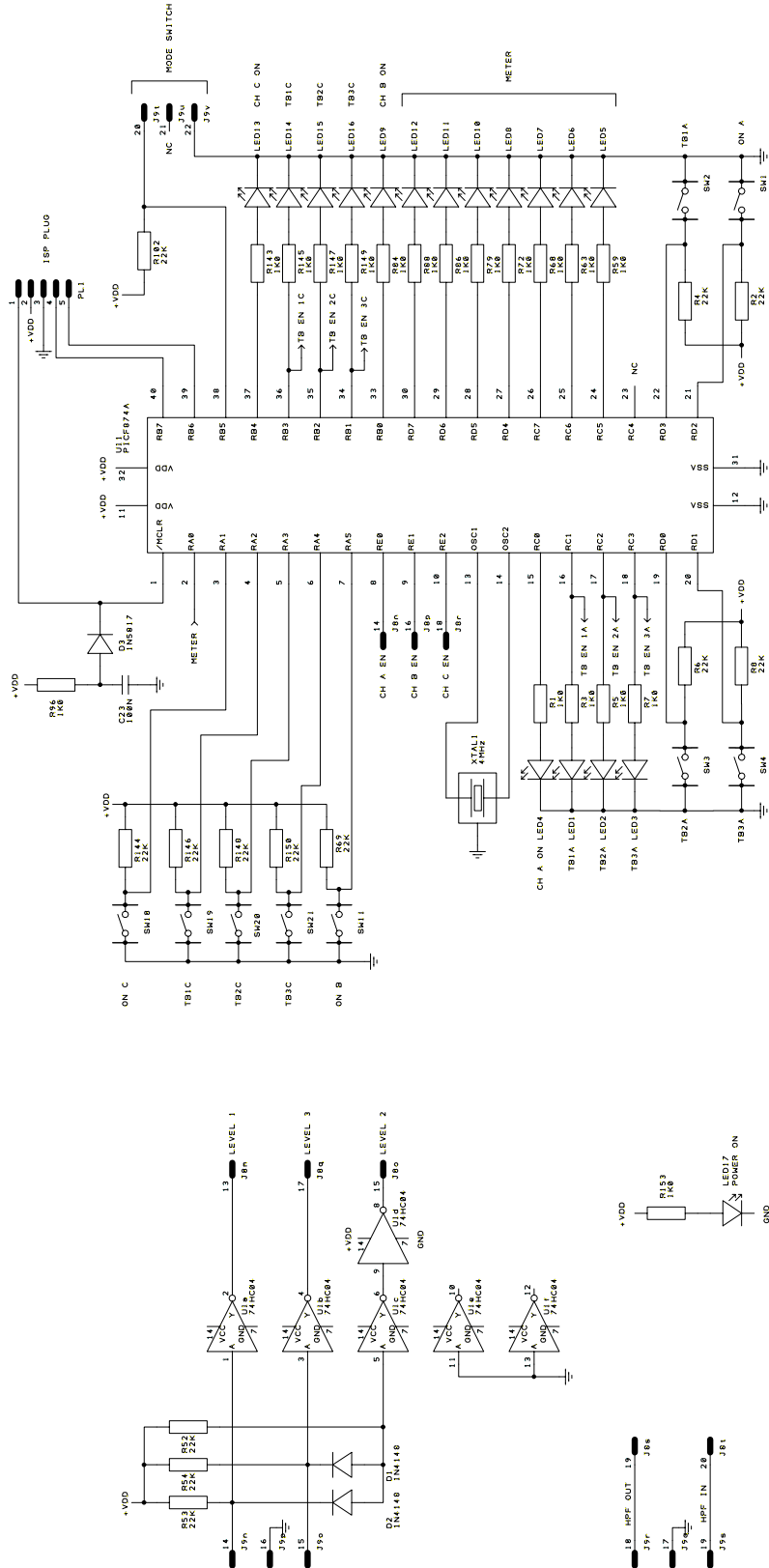

(C) GLENSOUND

ISSUE 2

SUBJECT GS-CU001 CONTROL PANEL MICROCONTROLLER SECTION

DATE 8/5/03

DRG. REF. GSR32 SHEET 3

DRAWN SJL

G GLENSOUND
ELECTRONICS LTD.

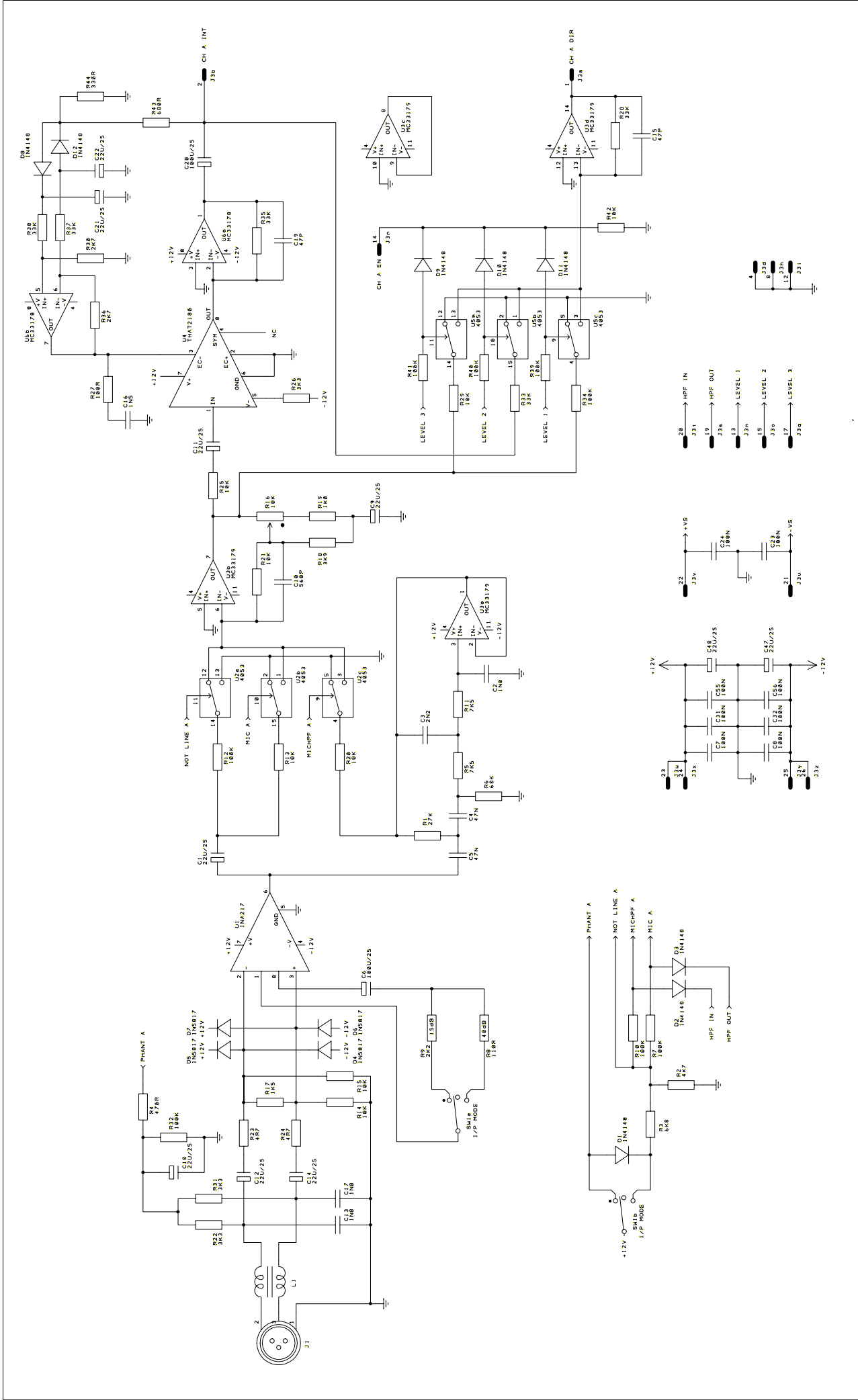

(C) GLENSOUND			G GLENSOUND ELECTRONICS LTD.	
ISSUE	3	SUBJECT 'COMM. UNIT TRIPLE I/P INPUT A		
DATE	8/5/03	DRG. REF. ' GSR33 SHEET 1		
DRAWN	S.J.L.			

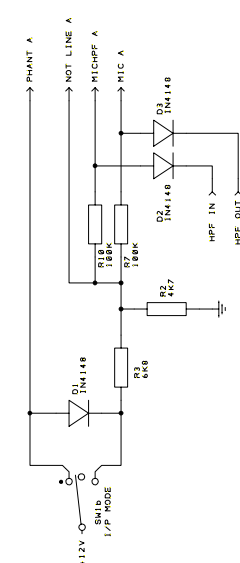
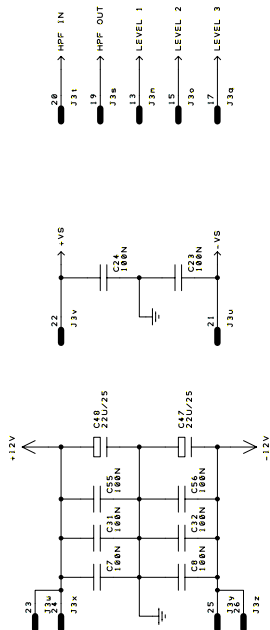
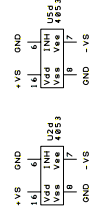

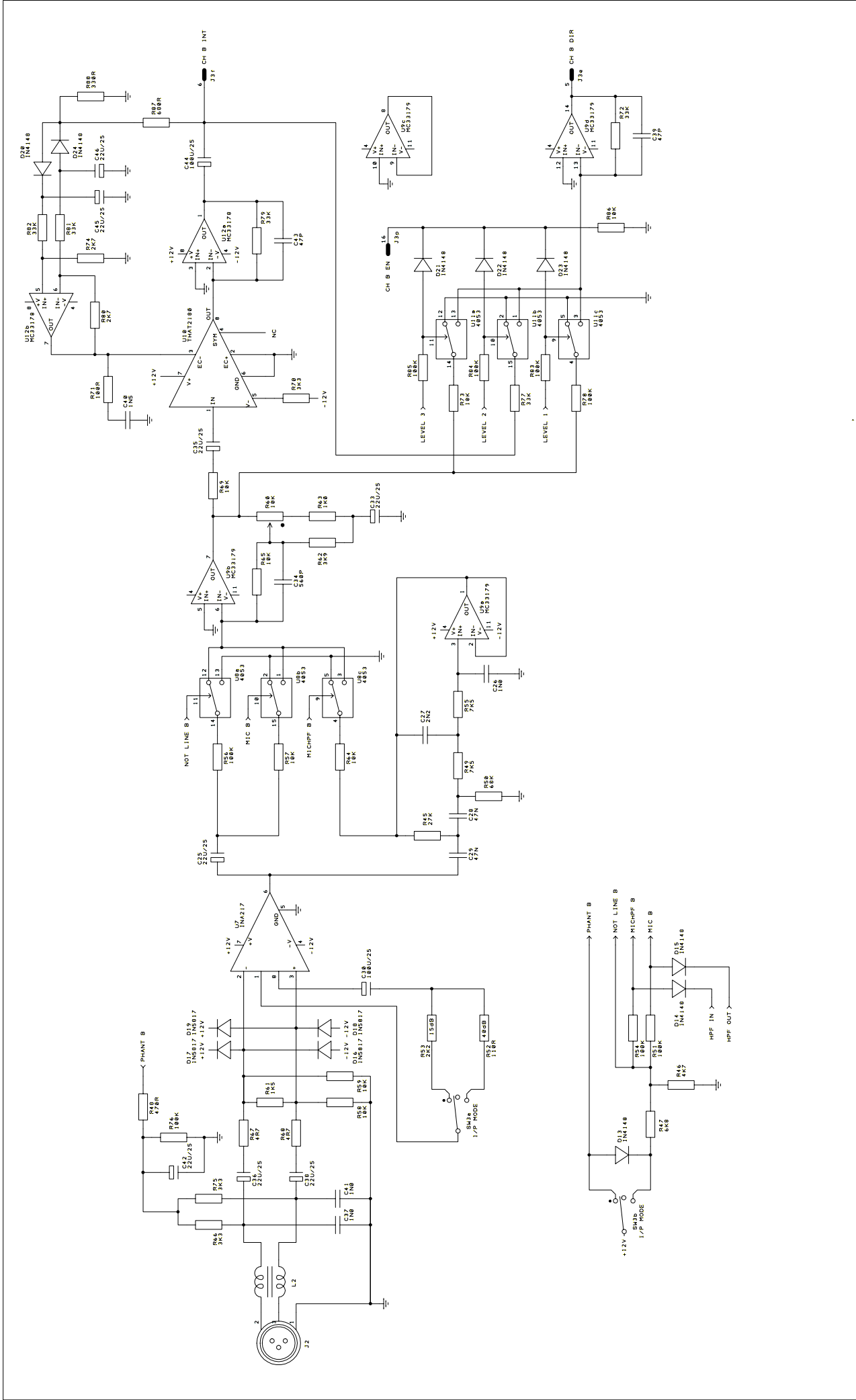

(C) GLENSOUND			G GLENSOUND ELECTRONICS LTD.	
ISSUE	3	SUBJECT COMM. UNIT TRIPLE I/P INPUT B		
DATE	8/5/03	DRG. REF. GSR33 SHEET 2		
DRAWN	S.J.L.			

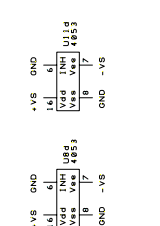

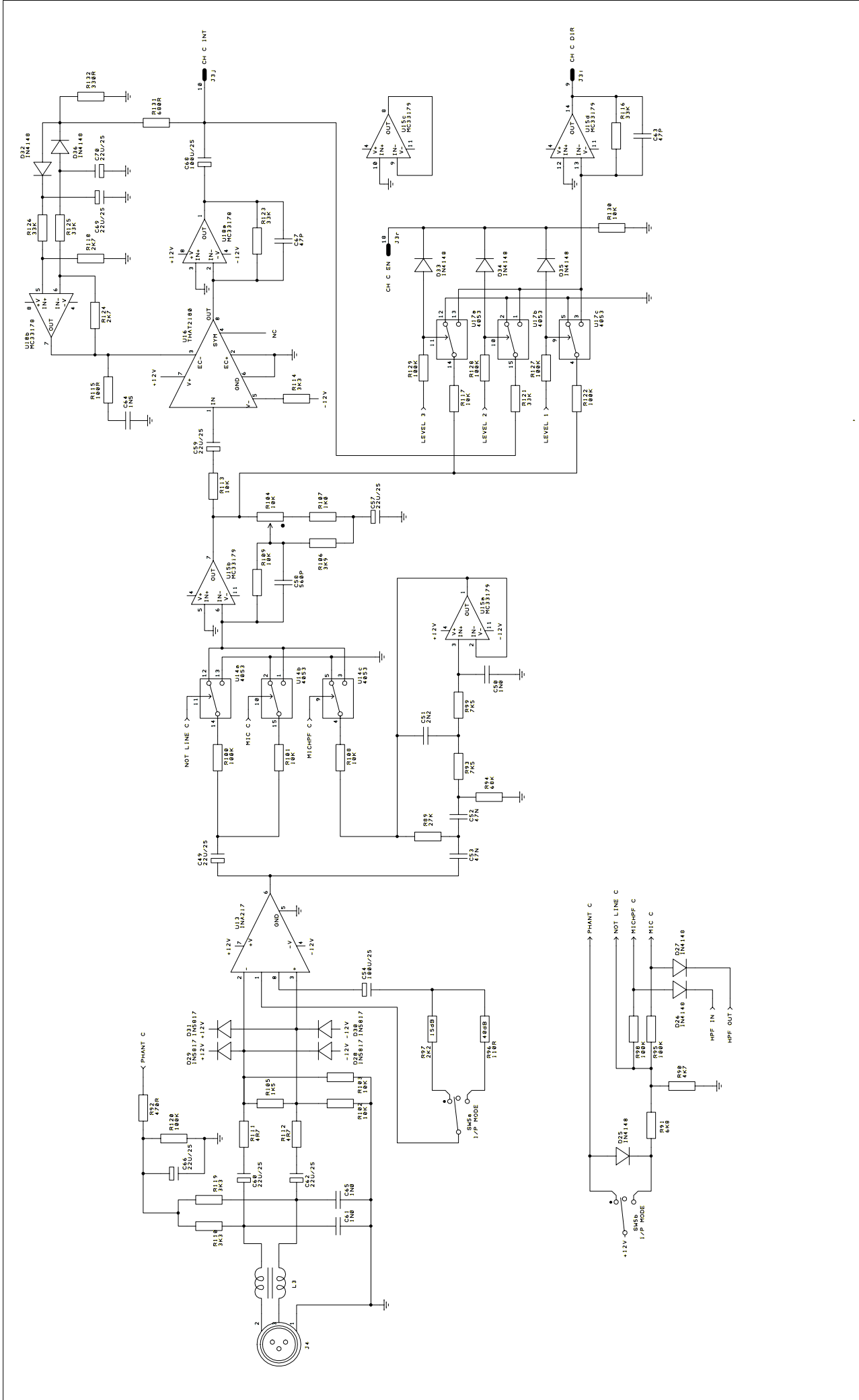

(C) GLENSOUND			G GLENSOUND ELECTRONICS LTD.
ISSUE	3	SUBJECT	COMM. UNIT TRIPLE I/P INPUT C
DATE	8/5/03	DRG. REF.	GSR33 SHEET 3
DRAWN	S.J.L.		

